



Applied Pulsed Power™

A Division of Silicon Power Corporation

280 Great Valley Parkway
Malvern, PA 19355-1308

Phone: 610-407-4700
www.appliedpulsedpower.com

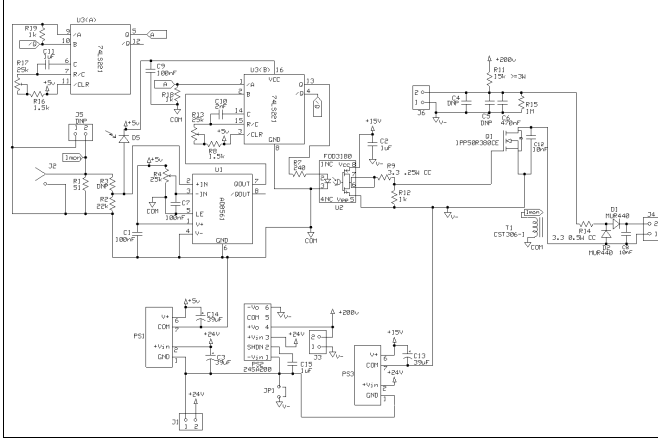

Model EA0046 High Power Solid State Switch Trigger Circuit

The Model EA0046 is designed to provide two parallel isolated outputs of 5A suitable for triggering our line of solid state switches, such as the Models S56 and S70. There are multiple trigger and power input options. The EA0046 is a higher power version of the EA0038.

This trigger circuit consists of a discriminator section, a driver section, and an isolation section. Optical isolation is used to separate the electrical trigger input signal from the driver section. This increases the noise immunity of this circuit. A high voltage 3W DC to DC converter is used to provide higher trigger output power. The isolated output versions output pulse width are limited by the saturation of the isolation transformer. All versions output pulse width and operational frequency are limited by capacitor selection. The end user should specify desired pulse width and frequency as well as power and trigger input options. Alternatively, the user can choose the option of using an external high voltage power supply.

Options

Power Input ₁	<ul style="list-style-type: none"> ● 24VDC (default) ● 48VDC
Trigger Input	<ul style="list-style-type: none"> ● TTL via BNC (default) ● Fiber Optic ₂ ● Other Electrical Trigger Signal

Note 1: External Power Supply Must Be Regulated

Note 2: Fiber-optic triggering requires 1mW of 850nm light terminated in a ST connector. The OPV315YAT can be used for this. We recommend using 62.5/125µm multi-mode fiber-optic cable at minimum. 200/235µm HCS fiber can also be used.

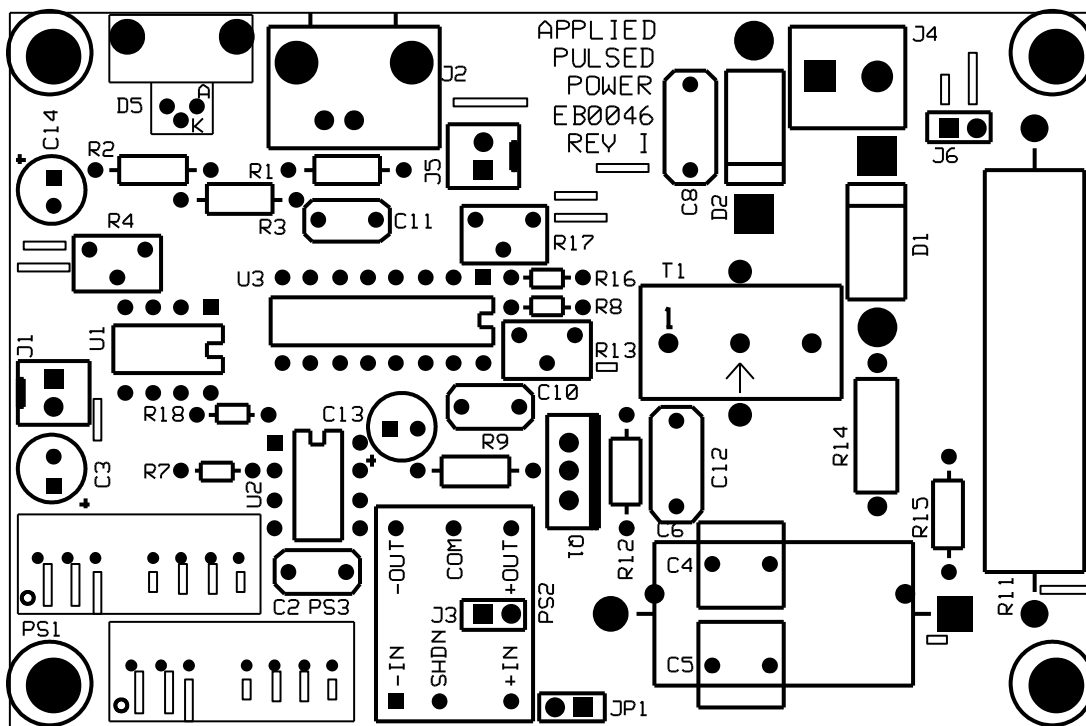

Figure 1: Model EA0046 Circuit Board Layout

Board Dimensions: 3.8"x2.5"

The four mounting holes are located 0.2" from the edges.

Figure 1 shows the layout of the connections for the EA0046 circuit board. The 24VDC is provided to pins 2 (+24VDC) and 1 (ground) of J1. J4 is the output with pin 1 being source and pin 2 being return. Pin 1 and 2 of J5 are only used for other electrical trigger inputs. J2 is the BNC trigger input while D5 is the fiber optic trigger input. PS2 is the high voltage DC to DC converter while J3 is only used for an external high voltage input with pin 1 (Vin-) and pin 3 (Vin+) instead of PS2.

R4 sets the trigger threshold. At 12.5 kohm across R4 the trigger threshold should be 2.5 V, sufficient for TTL circuit response.

R13 sets the pulse width out. At 12.5 kohm across R13 the pulse width will be about 20 usec. It is best to have this set just longer than the discharge pulse.

R17 sets the minimum time between pulses. At 12.5 kohm across R17 you should be at about 10 msec or a peak repetition rate of 100 Hz. It is best to have this set just above the desired operating frequency.